



We like...

- There is only one highest mountain in the world and this is the one
- A big page of climbing history was written on these slopes and continues to be written
- A summit day you will never forget on the ridge between Nepal and Tibet
- The life at Base Camp where you mix with climbers from all over the world
- The acclimatization on a beautiful 6,000 m peak (Island Peak) just behind Everest

Trip Facts

Elevation:	8,850 m / 29,035 ft
Location:	Nepal Khumbu Valley region
Climbing season:	April - May
Group Size:	3 – 10 people
Route	South West Ridge
Type of climb:	Snow / Ice, occasionally rock

Rating

Steepness	▲▲▲△△
Fitness	▲▲▲▲▲
Risk	▲▲▲▲△



Cian O'Brolcháin, World Sherpas partner, on Everest summit day

Why climb Everest with World Sherpas?

- The combined experience of clients and leading mountain guides into a single company
- A priority given to safety: procedures, training, equipment (avalanche beacon, radio, Garmin In Reach)
- A very comfortable set-up at Base Camp
- A real sharing of experience with our Sherpas throughout the expedition on climbing technique, physiology and effort management
- The use of Garmin InReach satellite systems for your family and friends to follow your progression every 10 minutes
- The production of beautiful photos and videos to always remember an extraordinary expedition
- An exceptional quality of services at the best price, inclusive of tips to the climbing guides and support staff



See dates on website or private trip
EVEREST – SOUTH WEST RIDGE

Price

US\$ 45,000
 Per Person

- Deposit: 30% at booking
- Balance: 70% two months before the departure date

<i>Included</i>	<i>Excluded</i>
<ul style="list-style-type: none"> ● All arrival and departure transfer services to and from airport (both domestic and international) ● Return domestic flight tickets Kathmandu / Lukla ● Transport of up to 2 duffle bags of a maximum total weight of 40 kgs. during the trek to Base Camp and on domestic flights ● 4 nights' accommodation at a good quality hotel in Kathmandu on B/B basis on a double basis (single option at extra cost) ● Accommodation in lodges during the trek ● Accommodation in spacious individual tents at Base Camp with foam mattress, carpets, light and storage space ● On High Camps, accommodation in shared expedition tents ● Qualified support team including experienced guides, cooks and porters ● Three meals a day (breakfast, lunch and dinner with tea or coffee) ● Climbing permit (11,000 US\$) and all fees and deposits required by the local regulations (e.g. line fixing, garbage deposit) ● 1:1 Experienced climbing sherpa per client on summit day (IFMGA Guide/Aspirant Guide) <p style="text-align: center;">.../...</p>	<ul style="list-style-type: none"> ● A summit bonus, or rather safety bonus, is expected by your climbing sherpa (US\$1,500) as well as tips to the kitchen staff and porters (US\$300) whatever happens on the mountain. This is now a practice well established in Nepal. The total amount of US\$1,800 should be deposited in cash to the Sherpa leader in Kathmandu at the beginning of the trip. If you want to add to the standard amount at the end of the trip, it is up to you but there is no obligation. ● Lunch and dinner in Kathmandu (except welcome dinner) ● Extras hotel charge at Kathmandu (bar bills, laundry, additional nights) ● Personal expenses in lodges during the trek such as battery charging (cameras, phone, laptops), showers, laundry, beverages, bottled water and snacks ● Additional nights in lodges during the trek not planned by us ● Internet access during the trek and at Base Camp (we can arrange a Nepalese SIM card and top-up card for you at Kathmandu for calls and internet) ● Personal trekking and climbing equipment (see gear list) ● Personal medical, travel & evacuation insurance (mandatory) ● International airfare ● Nepal entry visa fee

<i>...Included</i>	<i>...Excluded</i>
<ul style="list-style-type: none"> ● 8 oxygen bottles with a Summit mask and regulator (Climbing guides will also be on oxygen to ensure a maximum safety) ● First aid medical kit ● Registration and fee paid to the Everest Base Camp Medical Clinic ● Satellite phone at Base Camp (available to members as a paying service) ● Radio set for communication with Base Camp during climbing ● Garmin OutReach two-way satellite messaging system with satellite subscription ● Avalanche beacon ● Solar panel/generator for light and battery charger at Base Camp ● Welcome dinner in Kathmandu ● 2 x World Sherpas Duffle bags ● World Sherpas T-Shirt ● Set of quality photos / films taken by our guides 	



On the way to Camp 3 on the Lhotse face

Expedition Itinerary

Everest Base camp trek route

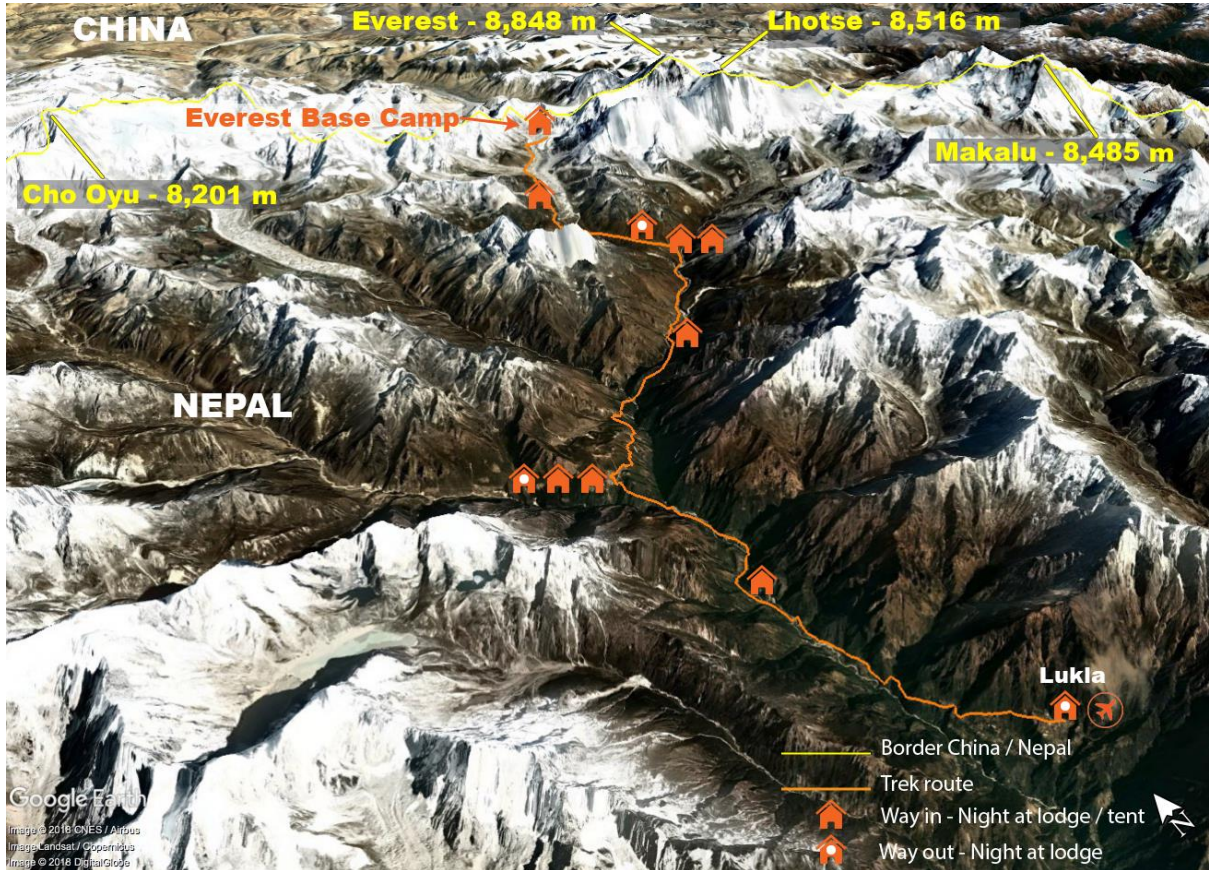

Lobuche Peak Climbing route





See dates on website or private trip
EVEREST – SOUTH WEST RIDGE

Day	Program
1	Arrival to Kathmandu and transfer to hotel (1,350 m / 4,430 ft)
2	Preparation day for expedition in Kathmandu
3	Fly to Lukla (2,860 m / 9,317 ft) and trek to Phakding (2,610 m / 8,562 ft)
4	Trek to Namche Bazaar (3,340 m / 11,155 ft)
5	Acclimatization day in Namche Bazaar
6	Trek to Pangboche (3,930 m / 12,893 ft)
7	Trek to Dingboche (4,410 m / 14,470 ft)
8	Acclimatization day in Dingboche
9	Trek to Lobuche village (4,940 m / 16,210 ft)
10	Trek to Lobuche Peak Base Camp (4,800 m / 15,750 ft) – Training session on fixed line
11	Climb Lobuche Peak (6,119 m / 20,075 ft) - and trek to Lobuche village
12	Trek to Everest Base Camp (5,345 m / 17,536 ft)
13-45	Climbing period on Everest (see detail on next page)
46	Trek to Pheriche (4,371 m / 14,340 ft)
47	Trek to Namche Bazaar (3,340 m / 11,155 ft)
48	Trek to Lukla (2,860 m / 9,317 ft)
49	Scheduled flight Lukla/Kathmandu & transfer to hotel
50	Reserve day at Kathmandu
51	Transfer to airport for departure

The itinerary is indicative and is subject to changes according to weather and mountain conditions as well as other circumstances that the climbing guide will deem necessary for the safety and / or success of the expedition.



See dates on website or private trip
EVEREST – SOUTH WEST RIDGE

Rotations provisional plan



Summit
 8,850 m / 29,035 ft

Camp 4
 7,950 m / 26,086 ft

Camp 3
 7,200 m / 23,625 ft

Camp 2
 6,400 m / 21,000 ft

Camp 1
 6,100 m / 20,013 ft

Base Camp
 5,345 m / 17,536 ft

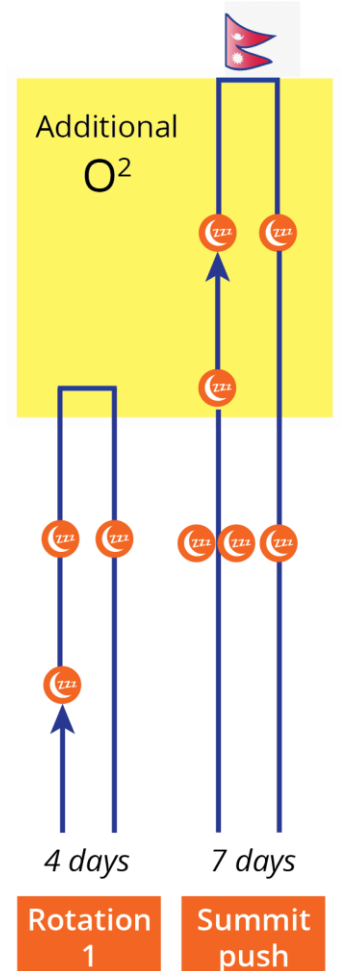

Everest Nepal Climbing Route





See dates on website or private trip
EVEREST – SOUTH WEST RIDGE

<p>Base Camp 5,335 m / 17,500 ft</p> <p>▼</p> <p>Camp 1 6,100 m / 20,013 ft</p> <p>5 hours</p>	<p>Base Camp is at the bottom of the Khumbu ice-fall. The ice-fall is the first section of the Nepal route to Everest and is a spectacular part of the climb. We travel through this maze of ice-blocks and crevasses during the night as it is colder and more stable. There are some steep sections and crevasse crossings that will require ladders. Usually, the route will change on each rotation due to movement of the glacier. Half way between base camp and camp 1, there is the football field, a nice flat area where we will rest, drink and prepare to climb the upper sections of the ice-fall. Once we finish negotiating our way through the upper sections of the ice-fall, we enter the Western Cwm and are treated to amazing views of Lhotse, Nuptse and Pumori. It is a relatively easy walk to camp 1 from the top of the ice-fall.</p>
<p>Camp 1 6,100 m / 20,013 ft</p> <p>▼</p> <p>Camp 2 6,400 m / 21,000 ft</p> <p>4 hours</p>	<p>We leave camp 1 early and start making our way up the Western Cwm. The Western Cwm is a flat, gently rising glacial valley. We cross some crevasses using ladders, lower down close to the base of Nuptse. There are also some crevasses in the central sections of the Cwm. We use fixed line in the lower sections above camp 1. There is not much wind in the valley as it is cut off from the mountains around us. This is one of the reasons why the valley heats up very quickly. There are spectacular views of Pumori, Nuptse, Lhotse and Everest.</p>
<p>Camp 2 6,400 m / 21,000 ft</p> <p>▼</p> <p>Camp 3 7,200 m / 23,625 ft</p> <p>5 hours</p>	<p>We leave camp 2, negotiating some small crevasses until we get back onto the Western Cwm snowfields. Once here, we make our way towards the large Bergschrund at the bottom of the Lhotse face. The normal route is direct, up the Lhotse face, using fixed line. The Lhotse face can be thick blue ice and is steep in parts. The average slope is 40/45°. On summit push, there are some good steps kicked in, making the climb to camp 3 less strenuous.</p>



See dates on website or private trip
EVEREST – SOUTH WEST RIDGE

<p>Camp 3 7,200 m / 23,625 ft</p> <p>▼ ▲</p> <p>Camp 4 7,950 m / 26,086 ft</p> <p>6 hours</p>	<p>Camp 3 rests on platforms dug out of the Lhotse face. We leave Camp 3 early to climb the fixed ropes towards the Yellow band. Fixed ropes assist us across this snow covered rock band. We traverse the Lhotse face, moving below Lhotse camp 4 before reaching the bottom on the Geneva Spur. The Geneva Spur is between 7,620 m / 25,000 ft and 7,924 m / 26,000 ft. It is a mixture of snow and rock scrambling. From the top of the Geneva Spur, the South Col can be seen and it is a short walk into camp 4.</p>
<p>Camp 4 7,950 m / 26,086 ft</p> <p>▼ ▲</p> <p>Summit 8,850 m / 29,035 ft</p> <p>8-12 hours</p>	<p>We leave camp 4 at night, and climb up the triangular face using fixed ropes. Once at the top of the triangular face, there is a small platform called the Balcony (8,400 m / 27,559 ft). This is a good place to have a small rest and take a drink. As we continue up the ridge, we are faced series of rock sections. The South Summit (8,750 m / 28,707 ft) is a small table sized dome of ice and snow. Another good place to take a rest and drink before the final summit push. From here, we follow the southeast ridge traversing along the most exposed part of the climb. On the left is the South West face (2,400 m / 7,900 ft) and on the right is the Kangshung Face (3,050 m / 7,900 ft). At the end of the traverse, we reach the bottom of the Hilary Step, a 12 m / 39 ft rock wall (8,790 m / 28,840 ft). Once above the step, it is a moderately angled slope to the summit. The summit is narrow and 1-2 people can stand on it at the same time. Incredible views of surrounding peaks, Makalu, Lhotse, Nuptse, Ama Dablam and other peaks. Climbers usually spend between 10-30 minutes on summit before going back to Camp 4 for a good night rest.</p>

Base Camp set-up

- Individual spacious tents with mattress, pillow, and light
- Toilet tent
- Shower tent (with hot water available on request)
- Mess tent for meals with table, chairs and cutlery
- Snacks / tea / coffee available during the day
- Heating of mess tent during dinner

Communications

- Cell phone network is usually available at Base Camp (Ncell as a service provider) but the service is patchy
- Internet is also available (1 GB for \$43 in 2018) and more or less reliable depending on the day
- Company satellite phone is for emergency situations but is available for fee at Base Camp



Sunrise from Everest summit at 8,400 m / 27,559 ft with Makalu in the background